



The NL-01 InoxLaser uses time-of-flight laser technology for continuous non-contact distance or level measurement.

Able to measure to any solid surface, at any angle, the NL-01 an ideal sensor for level, positioning and detection applications.

Features

- Non-contact measurement with laser technology
- Level, distance & position measurement of solids
- 303 Stainless steel housing
- Measurement range up to 50 m (164')
- Continuous measurement, 10 mm (0.39") resolution
- NAMUR compliant 4 ... 20 mA output
- 2 Normally open relay outputs
- Easy configuration via USB
- Optional Dust tube accessory (NL-01/DT) and Swivel mounting bracket (NL-01/SB)

Applications

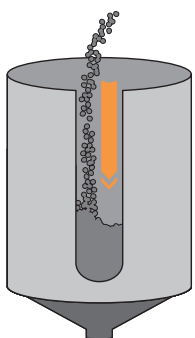

Level control

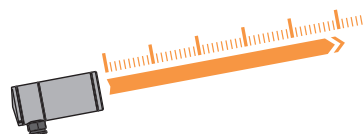

Distance measurement

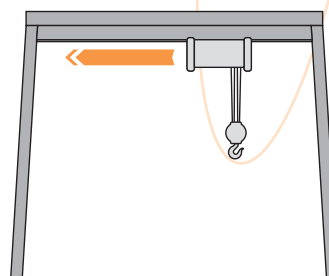

Positioning

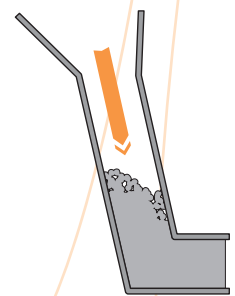

Blockage detection

Table of contents

1. Quick start guide	3
2. Connections.....	4
3. Instructions for safe use	5
Appendix A :: Specifications	6
Appendix B :: Dimension drawings.....	6
Revision history.....	7

Table of figures

Figure 1 :: Connection diagram	4
Figure 2 :: Labelling on the NL-01	5
Figure 3 :: Dimension drawings of the NL-01	6

Disclaimer

Information found in this document is used entirely at the reader's own risk and whilst every effort has been made to ensure its validity neither LightWare Optoelectronics (Pty) Ltd nor its representatives make any warranties with respect the accuracy of the information contained herein.

1. Quick start guide

1. CAUTION - The NL-01 InoxLaser Sensor contains a laser and should never be aimed at a person or an animal. Do not look at the beam directly with optical instruments.
2. Download LightWare Terminal software from www.lightware.co.za > Info > Software onto your PC. Open the installer package and follow the installation instructions. Everything needed for communicating with the NL01 will automatically be installed.
3. Connect the 24 V power supply, the 4 ... 20 mA output, and the relays, as necessary for your application.
4. Plug a USB cable into the USB A connector in the terminal compartment of the NL-01.
5. Plug the other end of the USB cable into a PC and run the LightWare Terminal software program.
6. Press the “Connect” icon. The display will indicate the distance measured in meters and the signal strength as a percentage.
7. To access the “Home” menu, press the arrow up ↑ key.
8. Use the arrow left ← and right → keys to access the “4 ... 20 mA Controls”, “Relay Controls” and “Laser Controls” menus. Select a sub-menu item using the relevant numeric key. Type new values as a numeric string or as a toggling selection, and use Enter ↵ key to save and exit. A summary of the menu structure is given below:

Menu	Selection	Default	Range of values	Description
Home	N/A	** Serial #___ **	N/A	General information regarding the NL-01.
4 ... 20 mA Controls	4 mA	0.60 m	0.00 ... 50.00 m	Distance corresponding to the 4 mA output value.
	20 mA	25.00 m	0.00 ... 50.00 m	Distance corresponding to the 20 mA output value.
	Fail safe	Hold	<3.6 ... Hold ... >21.0 mA	Failsafe condition of the 4 ... 20mA range for alarm indications.
	Fail time	4.00	0.00 ... 600.00 s	Delay time between failure and failsafe.
	Test	--.-- mA	4.0 ... 12.0 ... 20.0 mA	Output test of the 4 ... 20 mA.
Relay Controls	Relay 1	1.00 m	0.00 ... 50.00 m	Distance at which Relay 1 activates.
	Relay 2	2.00 m	0.00 ... 50.00 m	Distance at which Relay 2 activates.
	Hysteresis	0.25 m	0.00 ... 2.00 m	Distance between activation and deactivation of the relays.
	Configure	Near closed / Far open	Near closed / Far open or Near open / Far closed	Relay configuration.
	Test relays	Open open	Open or closed	Tests relay functionality.
Laser Controls	Filtering speed	100.000 m/s	0.005 ... 100.000 m/s	Maximum filling speed of the vessel.
	Power	100%	100% ... 130%	Output power of the laser.

9. From each menu, use the arrow up ↑ and down ↓ keys to see the effects of changes to the settings.
10. Once all the settings are entered, go back to the “Home” menu and press the arrow down ↓ key restart normal measurements.

2. Connections

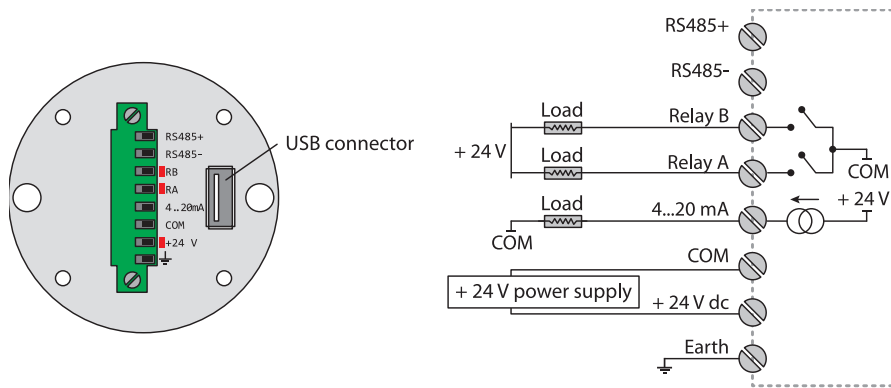

Figure 1 :: Connection diagram

NL-01

3. Instructions for safe use

The NL-01 is a laser rangefinder that emits ionizing laser radiation. The level of the laser emission is Class 1M which indicates that the laser beam is safe to look at with the unaided eye but must not be viewed using binoculars or other optical devices at a distance of less than 15 meters. Notwithstanding the safety rating, avoid looking into the beam and switch the unit off when working in the area.

CAUTION -- The use of optical instruments with this product will increase eye hazard.

The NL-01 should not be disassembled or modified in any way. The laser eye safety rating depends on the mechanical integrity of the optics and electronics so if these are damaged do not continue using the NL-01. There are no user serviceable parts and maintenance or repair must only be carried out by the manufacturer or a qualified service agent.

No regular maintenance is required for the NL-01 but if the lenses start to collect dust then they may be wiped with suitable lens cleaning materials. Make sure that the NL-01 is switched OFF before looking into the lenses.

The NL-01 should be mounted using the four holes provided in the circuit board. Do not hold or clamp the lens tubes as this may cause damage and adversely affect the laser safety rating.

Laser radiation information and labels

Specification	Value / AEL	Notes
Laser wavelength	905 nm	
Pulse width	< 20 ns	
Pulse frequency	< 36 kHz	
Peak power	< 10 W	50 millimeter aperture at 2 meters
Average power	< 0.6 mW	7 millimeter aperture
Average energy per pulse	< 300 nj	
NOHD	15 m	Distance beyond which binoculars with may be used safely

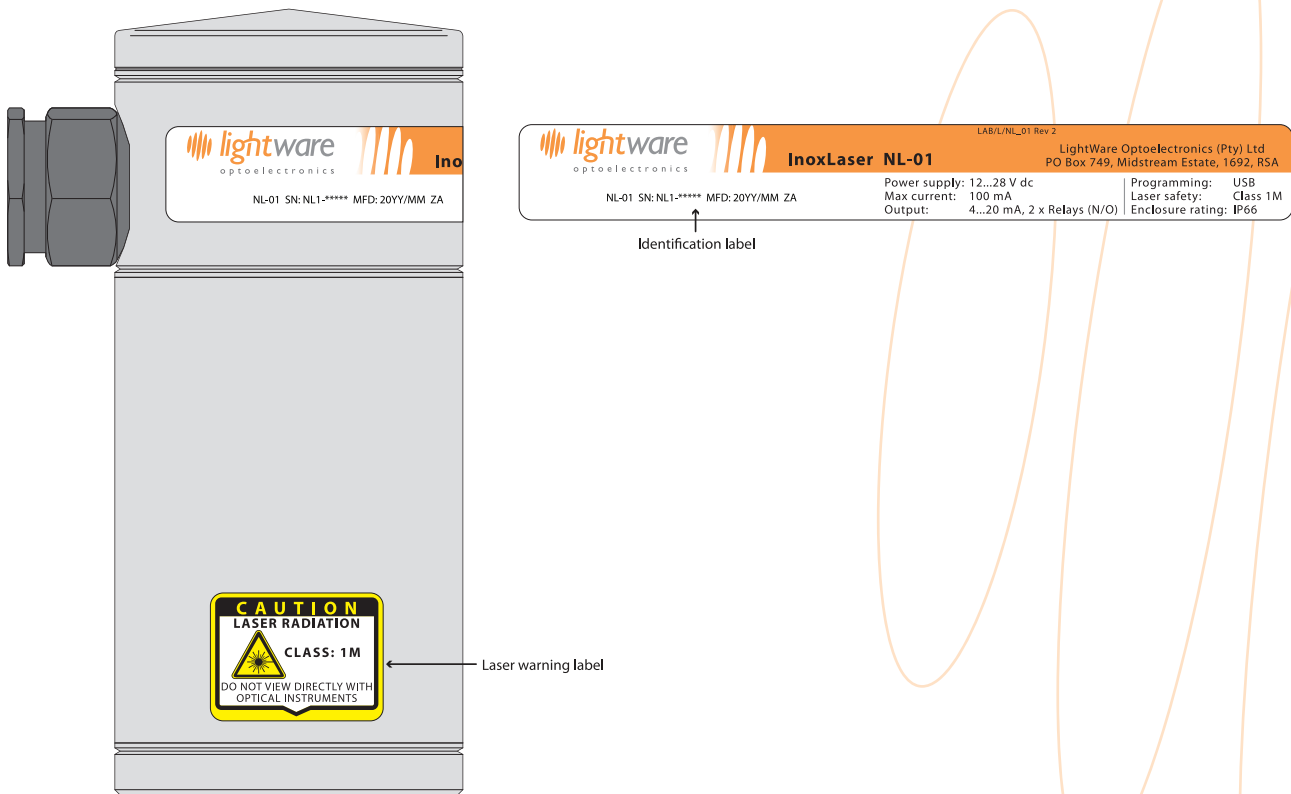

Figure 2 :: Labelling on the NL-01

Appendix A :: Specifications

Performance data	
Sensing range	0.3 ... 50 m (0.98' ... 164')
Resolution	1 cm (0.39")
Accuracy	<0.1% of full range at 20°C
Update rate	5 readings per second
Technical data	
Power supply	24 V dc nominal (12 ... 28 V dc)
Current consumption	100 mA nominal
Output	
Analog	4 ... 20 mA NAMUR compliant self-powered & non-isolated. 2 x Relays (N/O), 250 V at 3 A.
Communication	USB at 115200 baud 8-N-1
Mechanical data	
Diameter	NL-01: 6.35 cm (2.36") NL-01/DT: 14 cm (5.51")
Length	NL-01: 14.4 cm (5.51") NL-01/DT: 20 cm (7.87")
Weight	NL-01: 1.25 kg (2.76 lb) NL-01/DT: 0.83 kg (1.83 lb)
Connection	Flange accessory (NL-01/DT) with 4 Ø 0.85 cm holes on 120 PCD
Housing material	303 Stainless steel
Optical data	
Optical aperture	6 cm (2.36")
Beam divergence	< 1° to half power points
Lens material	Impact resistant acrylic
Laser safety classification	Class 1M CAUTION: Do not view laser directly with optical instruments
Environmental data	
Operating temperature	-20°C ... +60°C
Pressure	Atmospheric
Enclosure rating	IP66

Appendix B :: Dimension drawings

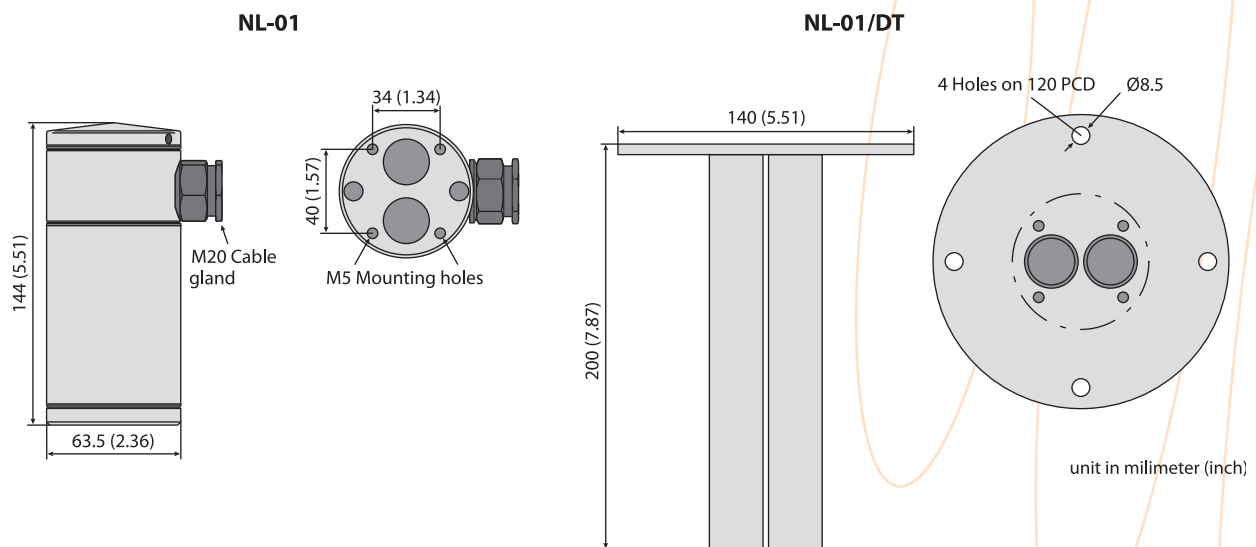

Figure 3 :: Dimension drawings of the NL-01

Revision history

Version	Date	Authors	Comments
Rev 1	2016/02/23	TLP	Increased weight specification of the NL-01 to 1.25 kg (2.76 lb) (page 6). Increased weight specification of the NL-01/DT to 0.83 kg (1.83 lb) (page 6). Increased NL-01/DT length to 20 cm (7.87") (page 6.)
Rev 0	2016/02/09	TLP	First edition

